

Compensation Plans

Compensation Chart & Examples

CUMULATIVE OVERRIDE ADVANCE:

This is money advanced to the first active upline Associate at a higher level.

ELITE COMMISSIONS:

Simply Performance Club qualify in one month to receive Elite commissions on sales processed the following month! (Minimum 65% rolling 12-month personal AND organizational retention required.).

Example A: If you are a Director, and your Sr. Manager personally recruits an Associate who makes his/her first sale, your advance would be the override above your **Sr. Manager**.

Your Sr. Manager would receive the advance override above his/her **Associate**.

If YOU are a/an	Personal Sales Advance		Cumulative Override Advances		
	ELITE	BASIC	DOWNLINE	ELITE	BASIC
Associate			N/A		
Sr. Associate			Associate		
Manager			Associate Sr. Associate		
Sr. Manager			Associate Sr. Associate Manager		
Director			Associate Sr. Associate Manager Sr. Manager		
Sr. Director			Associate Sr. Associate Manager Sr. Manager Director		

Example B: If you are a Silver ED, and your Bronze ED personally recruits an Associate who makes his/her first sale, your advance would be the override above your Bronze ED.

Your Bronze ED would receive the advance override above his/her Associate.

If YOU are a/an	Personal Sales Advance		Cumulative Override Advances		
	ELITE	BASIC	DOWNLINE	ELITE	BASIC
Executive Director			Associate Sr. Associate Manager Sr. Manager Director Sr. Director		
Bronze ED			Associate Sr. Associate Manager Sr. Manager Director Sr. Director Executive Director		
Silver ED			Associate Sr. Associate Manager Sr. Manager Director Sr. Director Executive Director Bronze ED		
Gold ED			Associate Sr. Associate Manager Sr. Manager Director Sr. Director Executive Director Bronze ED Silver ED		

Example C: If you are a Triple Plat. ED, and your Double Plat. ED personally recruits an Associate who makes his/her first sale, your advance would be the override above your **Double Plat. ED**.

Your Double Plat. ED would receive the advance override above his/her **Associate**.

If YOU are a/an	Personal Sales Advance		Cumulative Override Advances		
	ELITE	BASIC	DOWNLINE	ELITE	BASIC
Platinum ED			Associate Sr. Associate Manager Sr. Manager Director Sr. Director Executive Director Bronze ED Silver ED Gold ED		
Double Plat. ED			Associate Sr. Associate Manager Sr. Manager Director Sr. Director Executive Director Bronze ED Silver ED Gold ED Platinum ED		
Triple Plat. ED			Associate Sr. Associate Manager Sr. Manager Director Sr. Director Executive Director Bronze ED Silver ED Gold ED Platinum ED Double Plat. ED		

Example D: If you are a Diamond ED, and your Platinum Elite personally recruits an Associate who makes his/her first sale, your advance would be the override above your **Platinum Elite**.

Your Platinum Elite would receive the advance override above his/her **Associate**.

If YOU are a/an	Personal Sales Advance		Cumulative Override Advances		
	ELITE	BASIC	DOWNLINE	ELITE	BASIC
Platinum Elite			Associate Sr. Associate Manager Sr. Manager Director Sr. Director Executive Director Bronze ED Silver ED Gold ED Platinum ED Double Plat. ED Triple Plat. ED		
Diamond ED			Associate Sr. Associate Manager Sr. Manager Director Sr. Director Executive Director Bronze ED Silver ED Gold ED Platinum ED Double Plat. ED Triple Plat. ED Platinum Elite		

THINGS YOU NEED TO KNOW:

Commissions are paid based on membership premium sold, either personal, or when an eligible Associate on your team makes a sale. Commission amounts shown represent a one-year advance. If a membership cancels during the advance period, you will be charged back against future commission advances. Commissions are paid daily via direct deposit with a minimum of \$20, if you have submitted a processable membership during the month (or previous month if Executive Director). NOTE: When an Associate in your organization makes a sale, you will receive the Override Advance for each level between yourself and the next active Associate in your downline.

20/10 Residual Commission Plan:

Year 1: 12-Month Advance Commission | **Year 2:** 20% Residual Commissions!

10% Cash Residual Commission paid with member's 13th payment. (Accumulated and paid the following month). Deposited directly into your account! Plus additional 10% flat residual income. Applies to both organizational and personal business.

10% percent residual commissions is 10% percent of what you were originally paid on the sale or override. 10% residual year 2 and beyond is paid monthly for the life of the membership and applied to the debit balance.

When will I be paid? A one-time Cash Residual Commission equal to 10% of the original advance commission will be paid with the member's 13th payment and is not subject to chargebacks. Additionally, annual renewal commissions of 10% (of the original advance) will be paid as the member makes their monthly payment for the life of the membership. All renewal commission will be first applied to any outstanding debit balance you may have. Once the debit balance is recovered, future earnings will be paid to you.

Breakaways - Director & ED

Qualified Director (QD): Must qualify for Director Breakaway by qualifying for Performance Club previous month. Qualify one month to receive breakaways on sales made the following month.

PLUS! Platinum Breakaway Overrides! Receive this Breakaway on all membership premium written through three (3) generations of Platinum Executive Directors

Example: Qualified ED distance from the sale.

BREAKAWAYS	Director		Sr. Director		Executive Director	
	BASIC	ELITE	BASIC	ELITE	BASIC	ELITE
Breakaway 1						
Breakaway 2						
Breakaway 3						
Breakaway 4						
Breakaway 5						

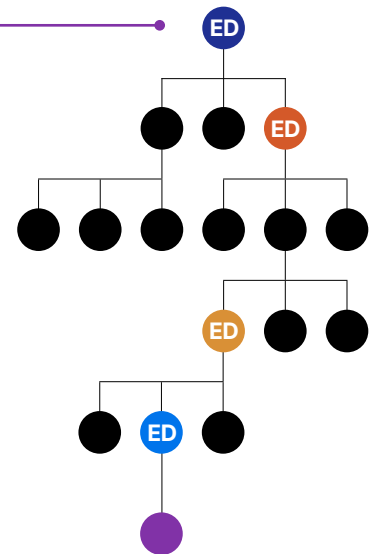

- Sale
- ED Override
- Breakaway 1
- Breakaway 2
- Breakaway 3

Associate Levels

1. ASSOCIATE — Welcome to Your Business: This is your starting level when you join LegalShield.

2. SR. ASSOCIATE: Achieve this level by enrolling 3 new unique members and 1 new personal recruit with an active membership or enroll 5 new unique members. *Fast Start: If you meet your Fast Start Qualification requirements you are eligible for additional bonus opportunities!*

3. MANAGER: Achieve this level by having 3 legs with an active Associate in each leg AND have \$300 organizational premium written OR personally sell \$500 in premium.

4. SR. MANAGER: Achieve this level by having 3 legs with an active Senior Associate in each leg AND have \$1,500 organizational premium written OR personally sell \$1,500 in premium. Minimum \$250 personal premium.

5. DIRECTOR: Achieve this level by having 3 legs with an active Manager in each leg AND have \$3,000 organizational premium written OR personally sell \$3,000 in premium. Minimum \$500 personal premium.

6. SR. DIRECTOR (Monthly Qualification): Achieve this level by being at Director level and having a minimum of \$700 premium written (including personal sales) with no more than \$350 premium written from 1 leg. Qualify in one month to receive commission increase on all organizational sales the following month.

7. EXECUTIVE DIRECTOR (Monthly Qualification): Achieve this level by being at Director level with \$1,400 premium written (personal or organizational), cannot count more than \$700 premium written from any 1 leg AND qualify for the Activity Requirement (see Executive Director and Above Activity Form on LSEngage.com). Qualify in one month to receive commission increase on all organizational sales the following month.

Elevated ED Levels

8. BRONZE ED : Qualify ED with 1 ED leg, or \$2,100 personal premium written.

9. SILVER ED: Qualify ED with 2 ED legs or \$2,800 personal premium written.

10. GOLD ED: Qualify ED with 3 ED legs or \$3,500 personal premium written.

11. PLATINUM ED : Qualify ED with 4 ED legs OR \$4,200 personal premium written.

12. DOUBLE PLATINUM: Qualify Platinum ED with 1 Platinum ED leg OR qualify Platinum ED with 6 ED legs OR \$5,600 personal premium written.

13. TRIPLE PLATINUM: Qualify Platinum ED with 2 Platinum legs OR qualify Platinum ED with 8 ED legs OR \$7,000 personal premium written.

14. PLATINUM ELITE: Qualify Platinum ED with 3 Platinum legs OR qualify Platinum ED with 10 ED legs, OR \$8,400 personal premium written.

15. DIAMOND ED : Qualify Platinum ED with 4 Platinum ED legs OR qualify Platinum ED with 12 ED legs, OR \$9,800 personal premium written.

Compensation is subject to change without notice and is subject to all company policies and procedures. All Associates with a production date prior to the last revision of the advancement criteria will need personal activity (which may include personal membership premium written or personal recruit) to promote through new advancement criteria. Organizational memberships include all personal and downline memberships. You will be charged a \$35 non-taken fee (in addition to the chargeback amount) for memberships on which money is not collected. The Company reserves the right to pay commissions on any sale based on actual payment received from the member (or as earned) or in certain cases to pay commissions on a modified structure which allows level commission earnings. NOTE: See LSEngage.com for complete details about compensation. For more information on additional earning opportunities go to LSEngage.com > Resources > Incentives.